

NELSON™ HEAT TRACING SYSTEMS

HASK-P HAZARDOUS AREA SEAL KIT

FOR DIV. 1 CABLE TERMINATION & EXPLOSION PROOF SEAL

INSTALLATION
INSTRUCTIONS

DESCRIPTION

The HASK-P Hazardous Area Seal Kit provides the cable termination and explosion proof seal parts needed to make the power end electrical connections associated with Nelson Heat Tracing Systems' self-regulating heater cables.

KIT CONTENTS

- | | |
|--------------------|---------------------|
| 1 Junction Box | 1 Stand-off |
| 1 Tube of Silicone | 1 Power Termination |
| 1 Sealing Compound | 1 Terminal Block |
| 1 Sealing Grommet | 1 X Fiber |
| 1 Conduit Plug | 1 Seal Fitting |
| 2 Pipe Clamps | 1 Male Adapter |

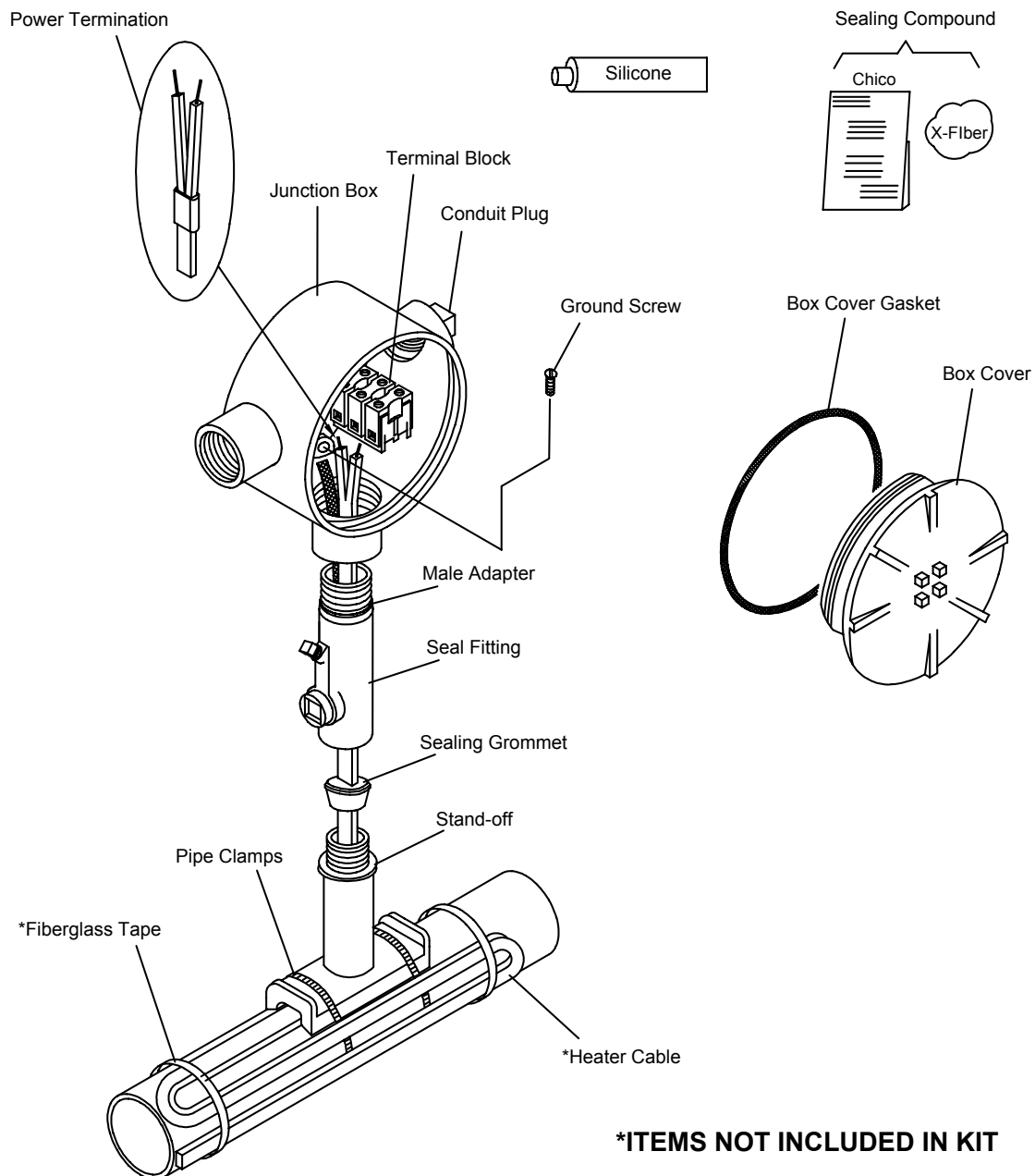

***ITEMS NOT INCLUDED IN KIT**

NELSON™ HEAT TRACING SYSTEMS

HASK-P HAZARDOUS AREA SEAL KIT

FOR DIV. 1 CABLE TERMINATION & EXPLOSION PROOF SEAL

INSTALLATION
INSTRUCTIONS

STAND-OFF POSITIONING

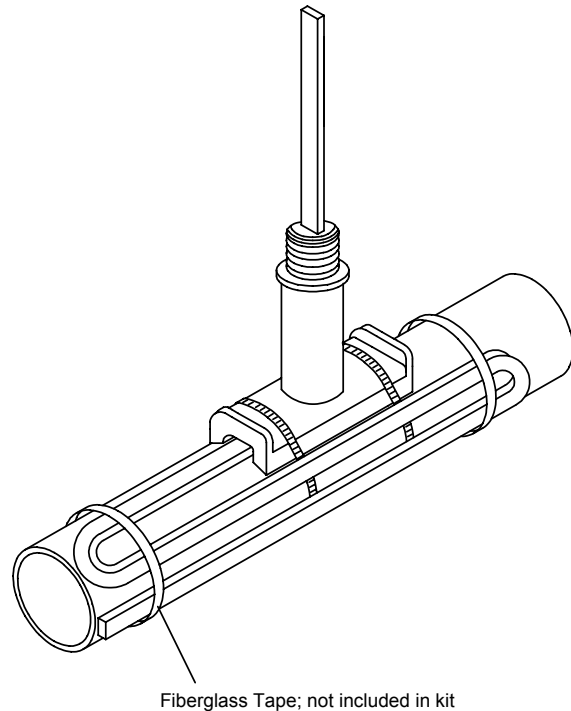
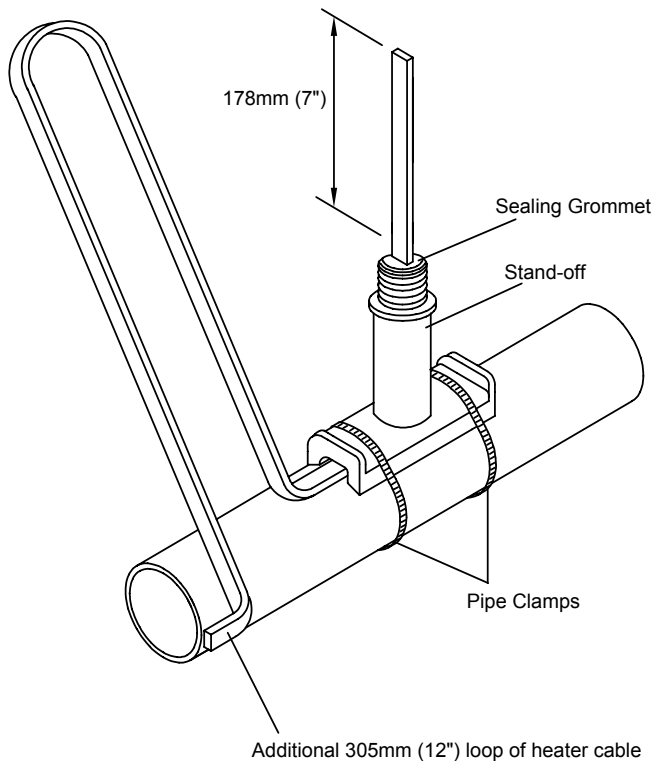

⚠ WARNING:

**Do not install pipe clamps
over the heater cable.**

- 1 Push heater cable through the bottom opening of the stand-off. Allow 178mm (7'') of heater cable for termination. Leave a 305mm (12'') loop of additional cable to be installed after the stand-off is secured.
- 2 Mount stand-off to pipe using the pipe clamps included in kit.
- 3 Slide the sealing grommet over heater cable and position at stand-off.

- 4 Secure the additional 305mm (12'') of heater to the pipe using fiberglass tape (not included in kit).
- 5 Prepare heater cable for termination. Proceed to "Overjacket Stripping Procedures" on sheet 3.

NELSON™ HEAT TRACING SYSTEMS

HASK-P HAZARDOUS AREA SEAL KIT

FOR DIV. 1 CABLE TERMINATION & EXPLOSION PROOF SEAL

INSTALLATION
INSTRUCTIONS

OVERJACKET STRIPPING PROCEDURES

⚠ WARNING:
DO NOT CUT BRAID

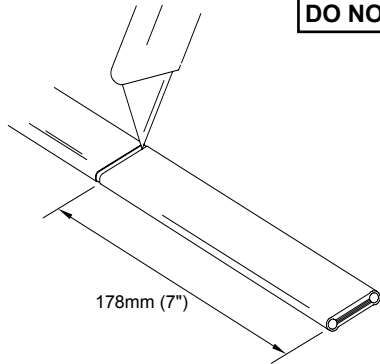

- 1 Lightly cut around heater overjacket 178mm (7") from the end. Bend cable to break overjacket.
- 2 Lightly cut overjacket up the center between first cut mark and the cable end. Bend cable to break overjacket.

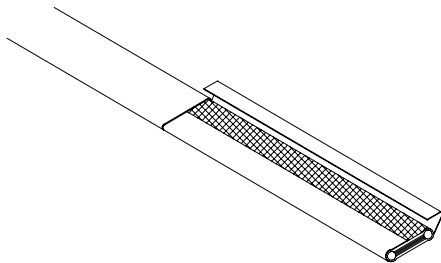

- 3 Remove overjacket from heater cable.

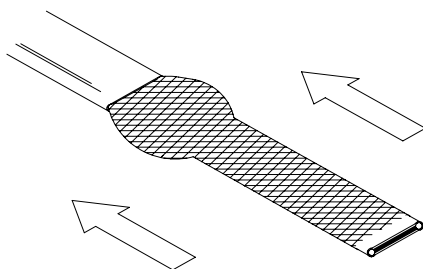

- 4 Move braid back toward the overjacket, creating a bulge.

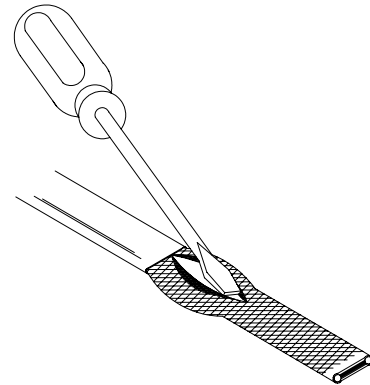

- 5 At the bulge, separate the braid to make an opening.

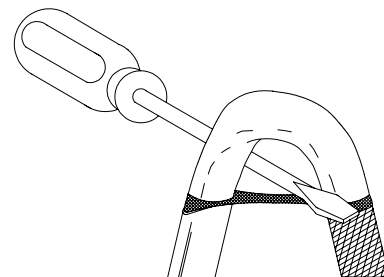

- 6 While bending the heater cable, work it through the braid opening.

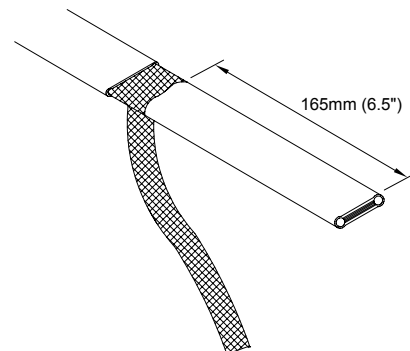

- 7 Pull the braid tight.
- 8 Proceed to "Outer Jacket Stripping Procedures" on sheet 4.

NELSON™ HEAT TRACING SYSTEMS

HASK-P HAZARDOUS AREA SEAL KIT

FOR DIV. 1 CABLE TERMINATION & EXPLOSION PROOF SEAL

INSTALLATION
INSTRUCTIONS

OUTER JACKET STRIPPING PROCEDURES

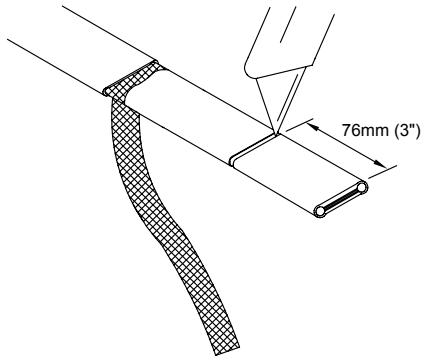

- 1 Lightly cut around heater outer jacket 76mm (3") from the end. Bend cable to break outer jacket.
- 2 Lightly cut the outer jacket up the center between the first cut mark & the cable end. Bend cable to break outer jacket.

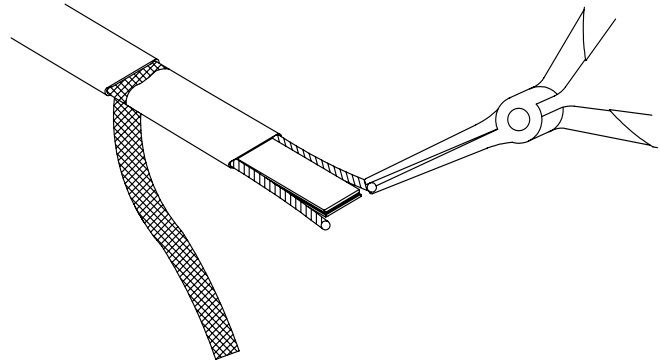

- 5 Starting at the end, pull each bus wire away from the core material.
- 6 Remove exposed core material.

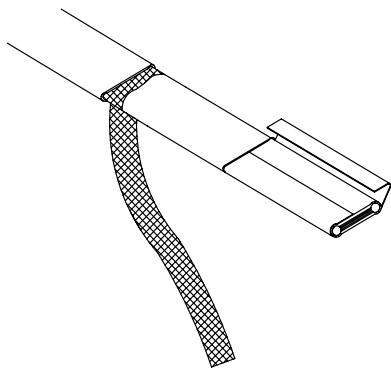

- 3 Remove the jacket from the heater cable.

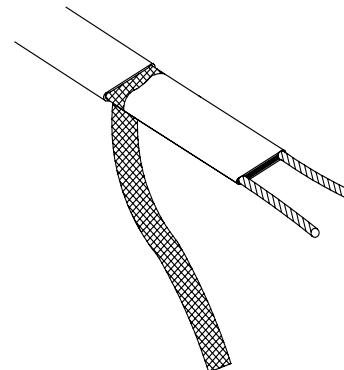

- 7 Cut 6mm (0.25") off the end of each bus wire.
- 8 Proceed to "Power Termination" on sheet 5.

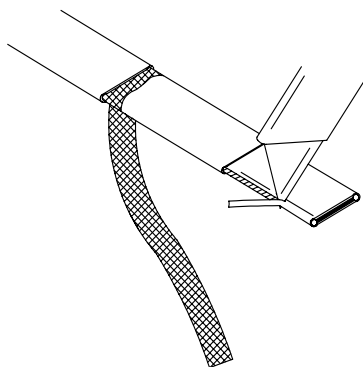

⚠ WARNING:
DO NOT CUT BUS WIRES

- 4 Shave the core material from the outside of each bus wire.

NELSON™ HEAT TRACING SYSTEMS

HASK-P HAZARDOUS AREA SEAL KIT

FOR DIV. 1 CABLE TERMINATION & EXPLOSION PROOF SEAL

INSTALLATION
INSTRUCTIONS

POWER TERMINATION

WARNING:

- Bus wires must not touch or cross while inserting into power termination.
- Only power terminations specifically approved for the vendors style and type of heater cable must be used.

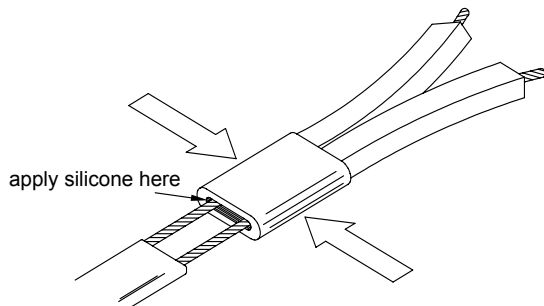

- 1 Insert bus wires into power termination.
- 2 Squeeze power termination opening and fill with silicone.

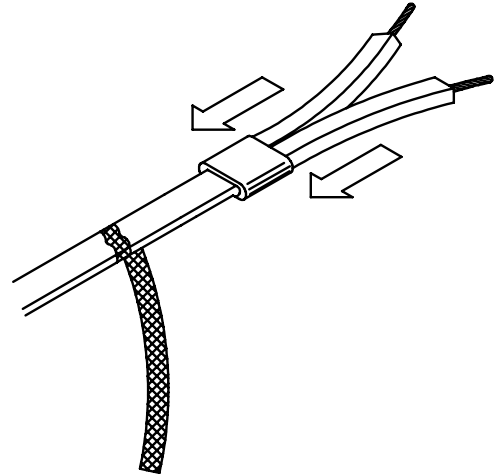

- 3 Push power termination to overlap jacket.
- 4 Proceed to "Seal Fitting Installation" on sheet 6.

NELSON™ HEAT TRACING SYSTEMS

HASK-P HAZARDOUS AREA SEAL KIT

FOR DIV. 1 CABLE TERMINATION & EXPLOSION PROOF SEAL

INSTALLATION
INSTRUCTIONS

SEAL FITTING INSTALLATION

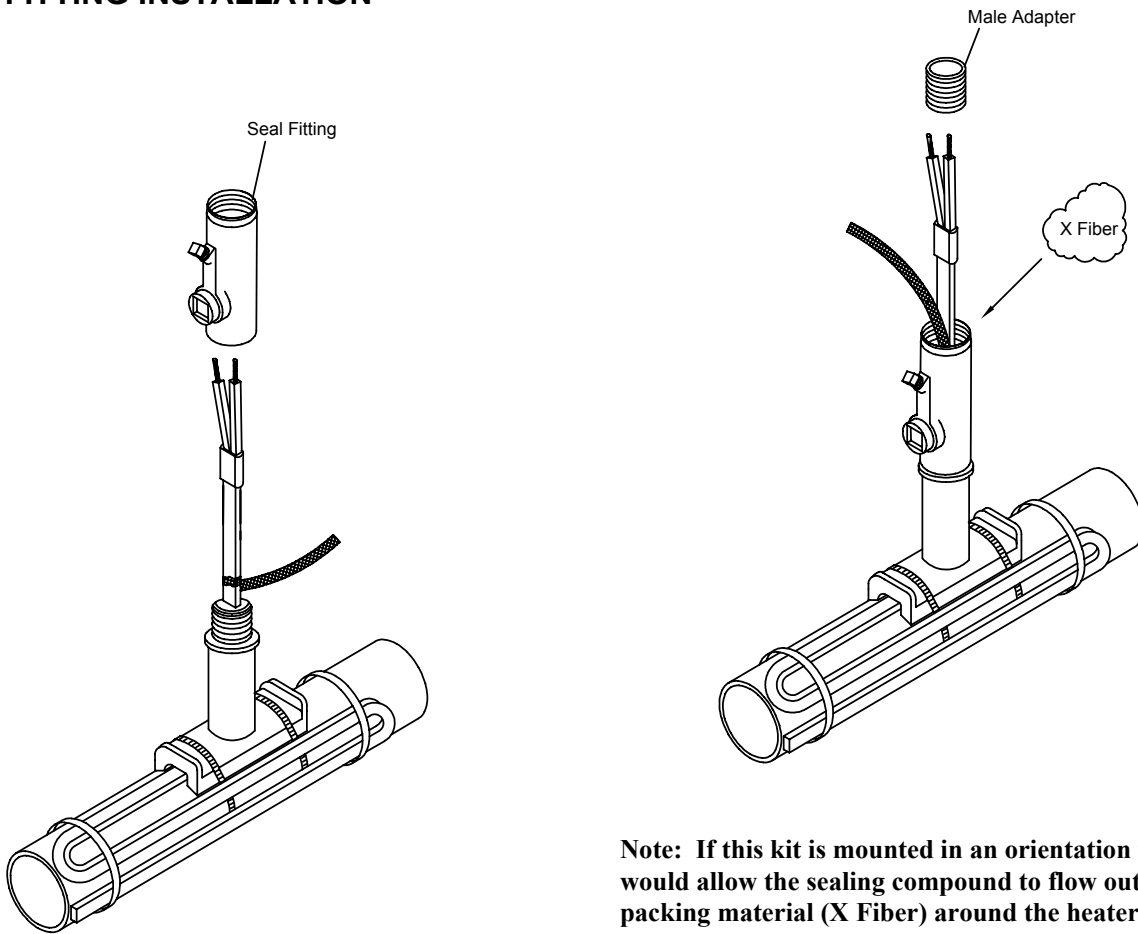

- 1 Slide seal fitting over the heater cable and braid, screw onto the stand-off by hand until snug fit.

Note: The heater cable must be positioned in the seal fitting so the braid transition point is visible through the seal fitting opening. See Detail "A" on sheet 8.

Note: If this kit is mounted in an orientation that would allow the sealing compound to flow out, place packing material (X Fiber) around the heater cable.

- 2 Slide male adapter over the heater cable and braid, screw into seal fitting by hand until snug fit.
- 3 Proceed to "Sealing Compound Procedure" on sheet 7.

NELSON™ HEAT TRACING SYSTEMS

HASK-P HAZARDOUS AREA SEAL KIT

FOR DIV. 1 CABLE TERMINATION & EXPLOSION PROOF SEAL

INSTALLATION
INSTRUCTIONS

SEALING COMPOUND PROCEDURE

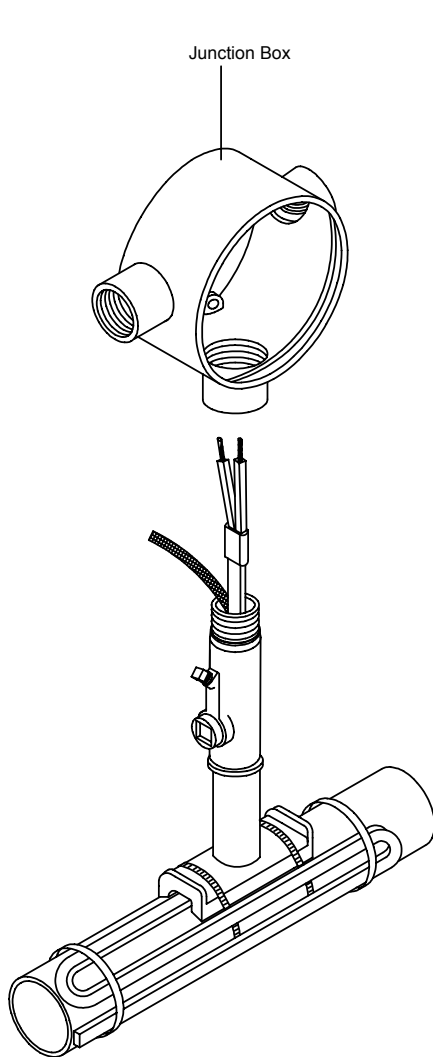

- 1 Place junction box over the heater cable and braid, screw onto male adapter until secure.

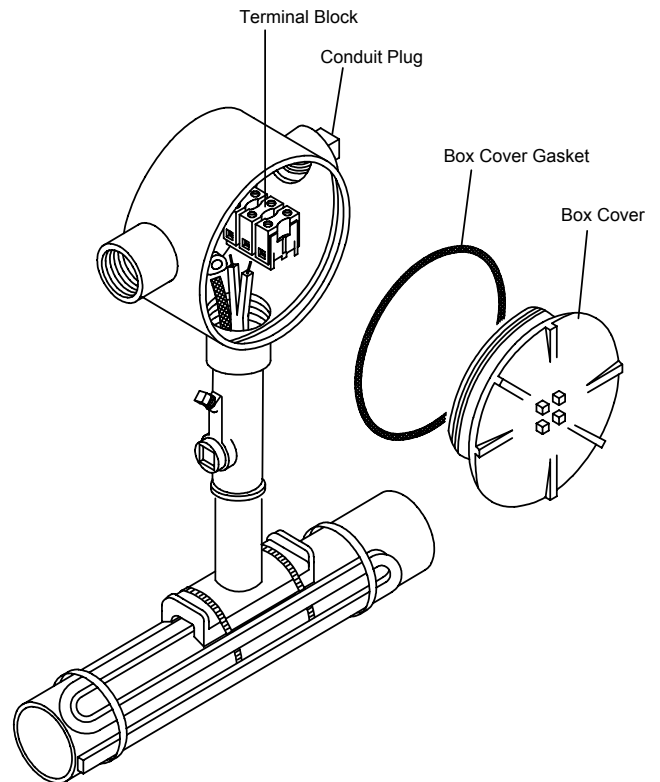

- 2 Connect bus wires to terminal block, one per terminal. Connect braid to green ground screw.
- 3 Place the box cover gasket and box cover onto junction box. Plug the unused conduit opening with the conduit plug.
- 4 Mix sealing compound according to the instructions on the pouch, (knead to mix liquid and powder in pouch). Snip off a corner of the pouch and fill the seal fitting.

⚠ WARNING:

Sealing compound must completely cover the braid transition point. See Detail "A" on sheet 8 for reference.

NELSON™ HEAT TRACING SYSTEMS

HASK-P HAZARDOUS AREA SEAL KIT

FOR DIV. 1 CABLE TERMINATION & EXPLOSION PROOF SEAL

INSTALLATION

INSTRUCTIONS

TEMPLATE

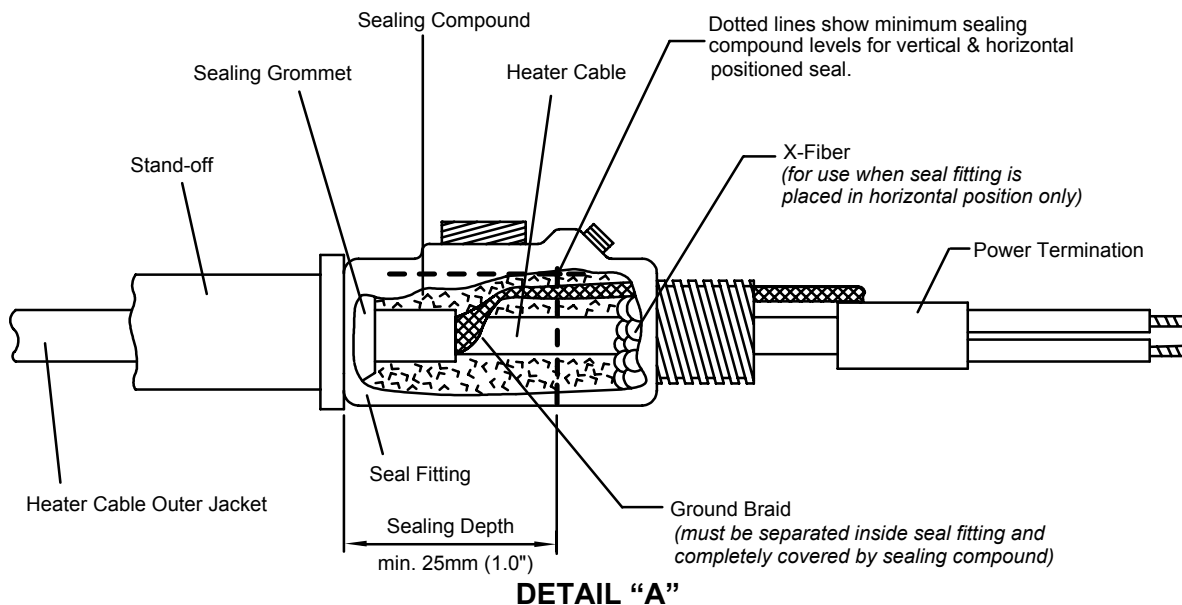
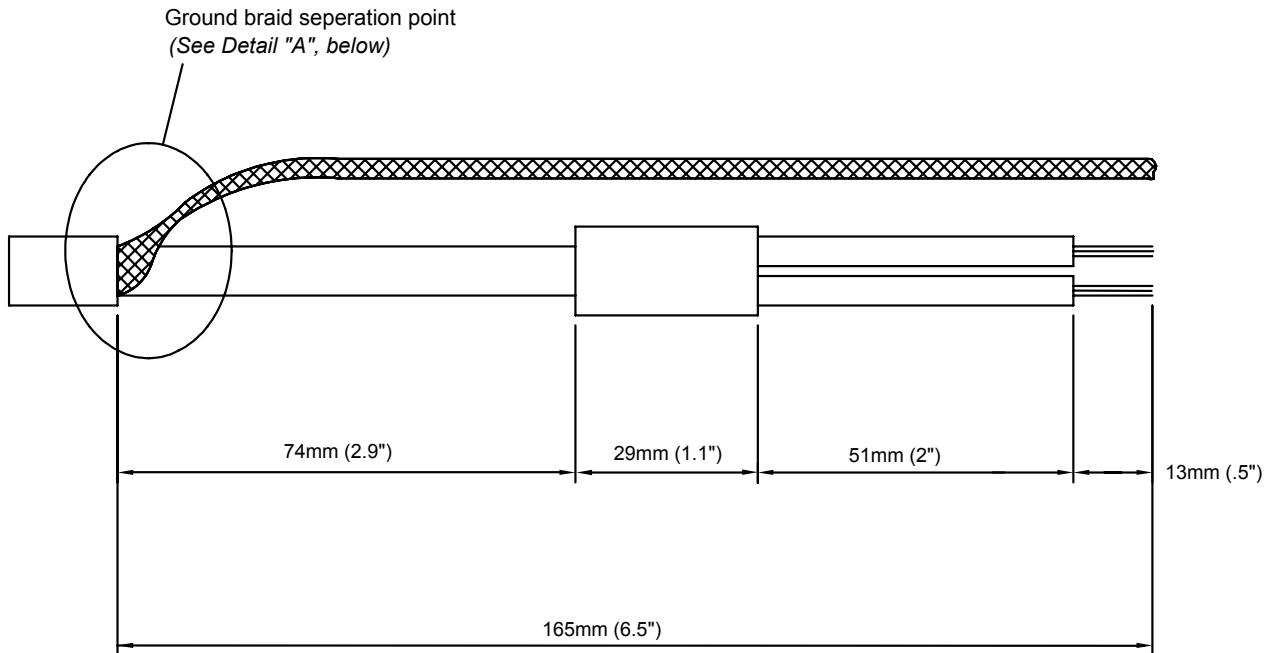

Nelson Heat Tracing Systems products are supplied with a limited warranty. Complete Terms and Conditions may be found on Nelson's website at www.nelsonheaters.com.

PO BOX 726 ■ TULSA, OK 74101 ■ (918) 627-5530 ■ FAX (918) 641-7336 ■ www.nelsonheaters.com

NELSON™

FM Division 1 Checklist for D1-LT and D1-HLT

Self-Regulating Heater Cable

As required by the Factory Mutual approval process, fill out this form and return to:

Nelson Heat Trace
P.O. Box 726
Tulsa, OK 74101

(or)

Nelson Heat Trace
Fax Number (918) 622-9308

Company Name

Purchase Order No.

Circuit Reference (ID Number)

Area Classification

Auto Ignition Temperature

Group

Substance

Heater Information

Cable Type

Voltage

Temperature Identification Number (T-rating)

Termination Kits

Power Connection

End Seal

Splice Connection

Tee Connection

Ground Fault Equipment Protection (Required)

Make and Model

Device Trip Level (mA)

Installation per Manufacturers Installation Instructions

Initials:

System Certification

Prepared By	Company	Date
Prepared By	Company	Date

This completed form must be returned to Nelson to complete the certification process. A copy of this completed form should be kept for installation record retention purposes.



NELSON HEAT TRACING SYSTEMS

P.O. Box 726 • Tulsa, OK 74101 • 918-627-5530 • Fax: 918-641-7336 • www.nelsonheaters.com

Form EQR-04-70103-D

Page 9 of 9